

# VDSL LINE TRANSFORMER

## CONEXANT ACCELITY I CHIPSET

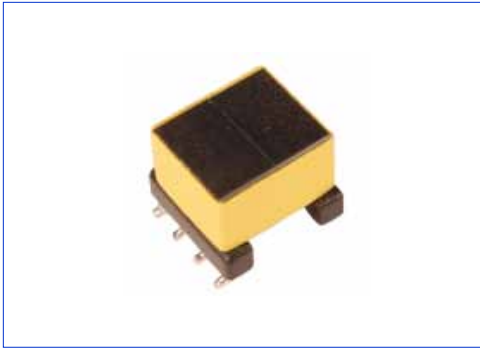

### B3336G



- RoHS Compliant Product
- Hipot: 1875VRMS 1 second (1,2,3,4 to 5,6,7,8)  
600VRMS 1 second (1,3 to 2,4)
- Operating Temp : -40°C to +85°C
- Meets requirements of EN60950 functional insulation
- 250V working voltage

### ELECTRICAL SPECIFICATION @ 25°C

PART NO	TURNS RATIO ±3% Line:Chip	Lp ±15% μH 1-4 (tie 2+3)	Insertion Loss 0.1-12MHz dB Max	Frequency Response 0.1-25MHz dB Max	Leakage Inductance μH Max 1-4	Longitudinal Bal dB Min 0.1-17MHz	THD dB Typ 25KHz
B3336G	1.1:1.0	800	-1.0	-3.0	1.0	38	70

### Mechanical

### Schematic

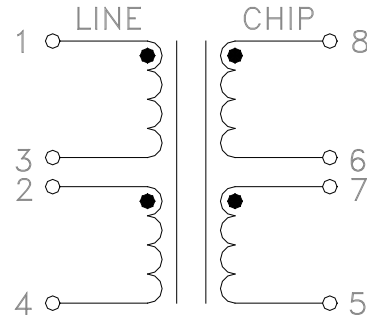
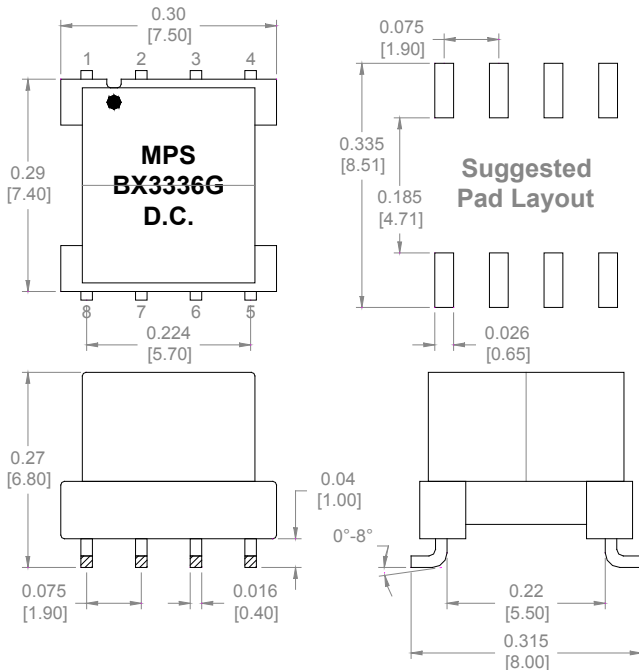

#### Dimensions

Unless otherwise specified, all tolerances are:  
 inch: .XX : ± 0.015 .XXX : ± 0.004  
 mm: X,X : ± 0,38 X,XX : ± 0,10

Product performance is limited to specified parameter. Data is subject to change without prior notice.

B3336G  
06231W